



DPCV+RO 3001
HIGH SPEED
PNEUMATIC LOADER
PRINT SYSTEM

SEMI AUTOMATIC ELECTRONIC DOSING AND PACKAGING SYSTEM FOR HIGH DEMANDING REQUIREMENTS.
COMPLETE WITH PNEUMATIC LOADER AND PRINT SYSTEM

DPCV - FILLING SYSTEM

ANALOGIC WEIGHING MANAGEMENT WITH VIBRATIONS INDEPENDENT CONTROL.

1 VIBRATING CHANNEL WITH CONSTANT VIBRATION SPEED, 2 VIBRATING CHANNELS (1 ROUGH, 1 FINE), 4 VIBRATING CHANNELS (2 ROUGH, 2 FINE), FOR AN UTMOST PRECISE DOSING.

1 WEIGHING HEAD.

ALL PARTS IN CONTACT WITH THE PRODUCT IN AISI 304 STAINLESS STEEL.

VERSIONS

AVAILABLE MOUNTED ON FLOOR SUPPORT WITH ADJUSTABLE IN HEIGHT AND DEPTH WORKING PLANE.

AVAILABLE WITH DIFFERENT LOADING HOPPER, WEIGHING TRAYS, UNLOADING HOPPER CONFIGURATIONS.

AVAILABLE ON DEMAND IN DIMPLE OR IN PTFE COATED PLATE.

AVAILABLE ALSO IN SPECIAL COUNTING VERSION, SPECIFICALLY DESIGNED FOR BAKERY PRODUCTS (EG. BREAD, BISCUITS, CROISSANTS).

AVAILABLE WITH COLOR TOUCH SCREEN INTERFACE.

ACCESSORIES

HOPPER, LOADING CONVEYOR, MAX PRODUCT LEVEL INDICATOR; FLANGES FOR COUPLING PNEUMATIC PRODUCT LOADER.



DPCV+RO 3001

HIGH SPEED PNEUMATIC LOADER PRINT SYSTEM

RO 3001 - ROTARY HEAT SEALING MACHINE

DESIGNED TO WORK WITH HIGH PERFORMANCE EVEN IN EXTREME WORKING SITUATIONS, WITH LONG SHIFTS, IN DIFFICULT ENVIRONMENTS AND WITH HIGH DEMANDING PRODUCTS.

STEEL AND ANODIZED ALUMINIUM CONSTRUCTION.

MAX SPEED UP TO 12 MT / MIN.

ADVANTAGE AND BENEFITS

- EXTREMELY **COMPACT**
- **MINIMAL** AND EXTREMELY **SIMPLE** MAINTENANCE
- **FLEXIBLE** AS IT IS DESIGNED AND BUILT TO WORK WITH ALL TYPES OF FLEXIBLE HEAT-SEALABLE MATERIALS AND AS AN INDEPENDENT SEALING MACHINE OR AS A SEALING STATION TO COMPLETE AUTOMATIC BAGGING LINES.
- RO 3001 CAN NOW BE EQUIPPED WITH THE NEW **MOTORIZED SUPPORT** AND BELT, DESIGNED TO SUPPORT AND ADJUST THE MACHINE AND MANAGE THE PACKAGING. THE VERTICAL ELECTRICAL ADJUSTMENT CAN BE MADE BY SIMPLY AND EASILY ACTING ON THE CONTROL PANEL.
- **INKJET CODING SYSTEM** WITH HP TECHNOLOGY AND KEYBOARDS TO ALLOW PRINTING OF MESSAGES WITH RESOLUTION UP TO 600 DPI IN 12.7 MM CONTAINING ALPHANUMERIC CHARACTER, BARCODES AND LOGOS.

VERSIONS

- ONLY SEALING HEAD
- MACHINE WITH SUPPORT AND INTEGRATED GRAVITY ROLLER
SPEED SYNCHRONISATION MACHINE/GRAVITY ROLLER
THE GRAVITY ROLLER CAN BE MANUALLY ADJUSTED IN HEIGHT.
- MACHINE MOUNTED ON MOTORIZED SUPPORT, GRAVITY ROLLER AS OPTION.
SPEED SYNCHRONISATION MACHINE/GRAVITY ROLLER
THE MOTORIZED SUPPORT CAN RAISE AND LOWER THE MACHINE AND THE GRAVITY ROLLER, WHEN EXISTING

ACCESSORIES UPON REQUEST

- MANUAL AIR EJECTION SYSTEM
- RL 500 - IN-FEED /EXIT STAINLESS STEEL LOADING GRAVITY ROLLER
- INK JET CODING SYSTEM



ERRORS/OMISSIONS EXCEPTED

DPCV+RO 3001

HIGH SPEED PNEUMATIC LOADER PRINT SYSTEM

RO 3001 MOTORIZED SUPPORT AND CONVEYOR

RO 3001 CAN NOW BE EQUIPPED WITH NEW MOTORIZED SUPPORT, DESIGNED TO MACHINE SUPPORT, ADJUST AND HANDLING.

THE ELECTRICAL VERTICAL ADJUSTMENT CAN BE CARRIED OUT THROUGH BUTTON PANEL.

THE MOTORIZED SUPPORT CAN BE COMBINED WITH THE NEW CONVOYER BAND.

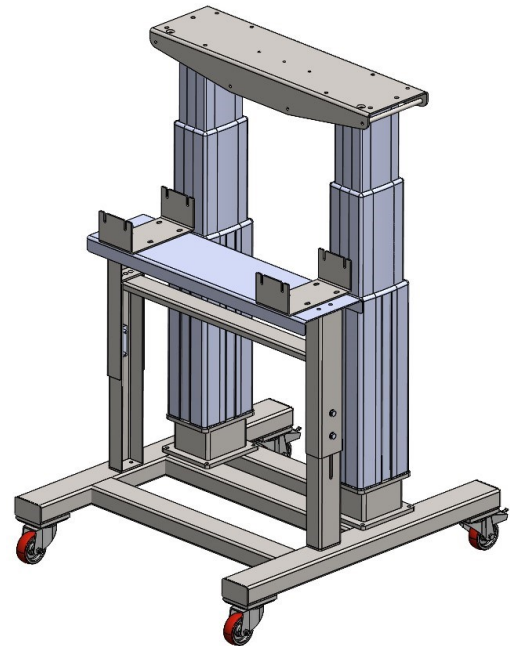

RO 3001 INK JET CODING SYSTEM WITH HP TECHNOLOGY + KEYBOARD

THE SYSTEM ALLOWS TO PRINT MESSAGES WITH A RESOLUTION UP TO 600 DPI IN 12,7 MM.,

CONTAINING ALPHANUMERIC TEXT, BARCODES AND LOGOS.

SYSTEM COMPOSED BY:

- PRINTING HEAD 12,7 MM
- SEPARATED KEYBOARD TO SET THE PRINTING STRING

TECHNICAL FEATURES

- PRINTING HEIGHT: UP TO 12,7 MM. FOR EACH HEAD
- ALPHANUMERIC DIGITS: ALL FONTS AND WIN95 FORMATS
- BARCODES (UPC, EAN13, CODE39, ITF, EAN128 ECC)
- CALENDAR, TIME AND COUNTER
- CONSTANT OR ADJUSTABLE PRINTING SPEED (CONTROLLED BY ENCODER)
- PRINTING HEAD CASE IN STAINLESS STEEL



DPCV+RO 3001

HIGH SPEED PNEUMATIC LOADER PRINT SYSTEM

RO 3001 TECHNICAL FEATURES

MATERIALS: ALL HEAT SEALABLE MATERIALS, CARTON HEADERS

BAGS: MAX 10 KG WEIGHT; MAX 560 MM HEIGHT

SEALING PROCESS: ROTARY CONSTANT HEAT

SEALING KIND ON REQUEST: FLAT, CRIMPED

SEALING SPEED: 3,5-12 MT/MIN, VARIABLE THROUGH INVERTER

SPEED ADJUSTMENT: THROUGH KAYPAD ON COMMAND PANEL

MAX SEALING HEIGHT 14 MM

MIN. DISTANCE SEAL/PROD. MM 40

FREE EDGE OVER SEALING MM 90

ADJUSTABLE SEALING PRESSURE

TEMPERATURE 20° ÷ 230° C (+/- 1%); ELECTRONIC THERMOREGULATOR WITH DIGITAL DISPLAY

IN-FEED RIGHT / LEFT; LEFT / RIGHT UPON REQUEST

PTFE BELTS DOUBLE RING MM 20

TOOTHED TRANSPORT BELTS

BUILT-IN GRAVITY ROLLER MM 1300 x 190

POWER SUPPLY 230 V – 50/60 Hz - SINGLE PHASE; AVERAGE ABSORPTION 650 W ; ACOUSTIC EMISSION LEVEL UNDER 70 dB(A)

DIMENSIONS (MACHINE) MM 1258 x 1266 x 564; WEIGHT: KG 115

CONSTRUCTION: CEI EN 60204-1,CE

MOTORIZED SUPPORT

VERTICAL ADJUSTMENT VIA BUTTON ON CONTROL PANEL

FRAME IN AISI 304 STEEL

LIFTING COLUMN IN ALUMINIUM

POWER SUPPLY 100-240 V; MAX ABSORPTION 300 W

WEIGHT: KG 113 (WITH GRAVITY ROLLER)

ACOUSTIC EMISSION LEVEL: 55 dB(A)

IP GRADE: IP20 - LIFTING COLUMN IP 65

CONSTRUCTION: CEI EN 60204-1,CE

ERRORS/OMISSIONS EXCEPTED